

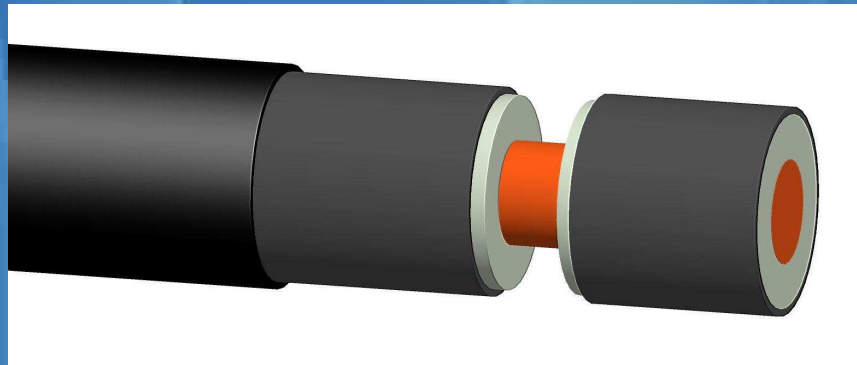

HV – INSULATION GROOVE & CHANNEL LHP5/50-160-NS-G50

L
H
P
5-
G50

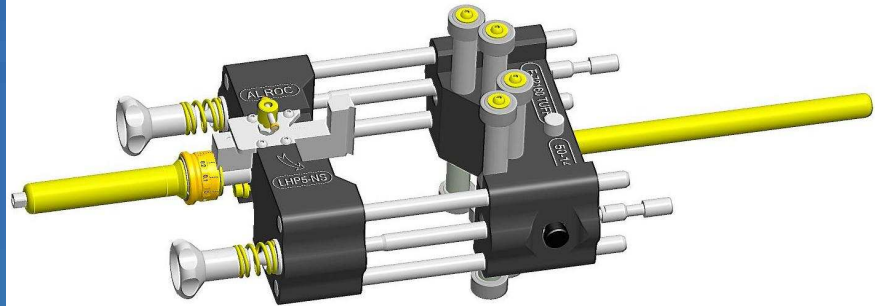

ALROC

Z.I de la fonderie
72160 Tuffé
FRANCE

Phone :

+33 (0)2 43 71 11 80

Fax :

+33 (0)2 43 71 16 51

www.alroc.fr

commercial@alroc.fr

FUNCTIONS

LHP5/50-160-NS-G50 tool allows to remove a part of the insulation and the semi-conductor to make a channel or a groove form.

This tool is used without lubrication and thrust

CHARACTERISTICS

Realization of a groove in the insulation.

Various blades add-ons can be mounted to realize any groove or channel shape. Custom shapes also possible.

Delivered in plastic case.

Blades add-ons are sold separately.

Capacity : $\varnothing 50$ to 160mm

L : 610 mm Weight : 10.1 kg

l : 226 mm

H : 122 mm